

F-2000B

SPEAKER SYSTEM

The F-2000 Series Speaker are compact two-way speaker systems designed for high efficiency, wide range, and high power input handling capability. These speaker systems can be installed in a manner ideal for the location and intended application.



Order no: F-2000B

Specifications

Frequency response	65 Hz - 20 kHz
Connection	Clamp terminal
Sensitivity (1#V, 1#m) (combined)	92 dB
Speaker component	Low: 20 cm cone-type, High: 2.5 cm balanced dome-type
Directivity angle horizontal	110 °
Directivity angle vertical	100 °
Rated impedance	8 Ω
Crossover frequency	3 kHz
Power handling capacity	60 W (continuous pink noise), 180 W (continuous program)
Weight	6,5 kg
Certificates	Ease
Dimensions (W x H x D)	244 x 373 x 235 mm
Dimensions (ø x D)	x 235 mm
Gross weight	8,5 kg
Finish	HIPS resin, black (RAL 9011 or equivalent)

F-2000B

SPEAKER SYSTEM

Appearance

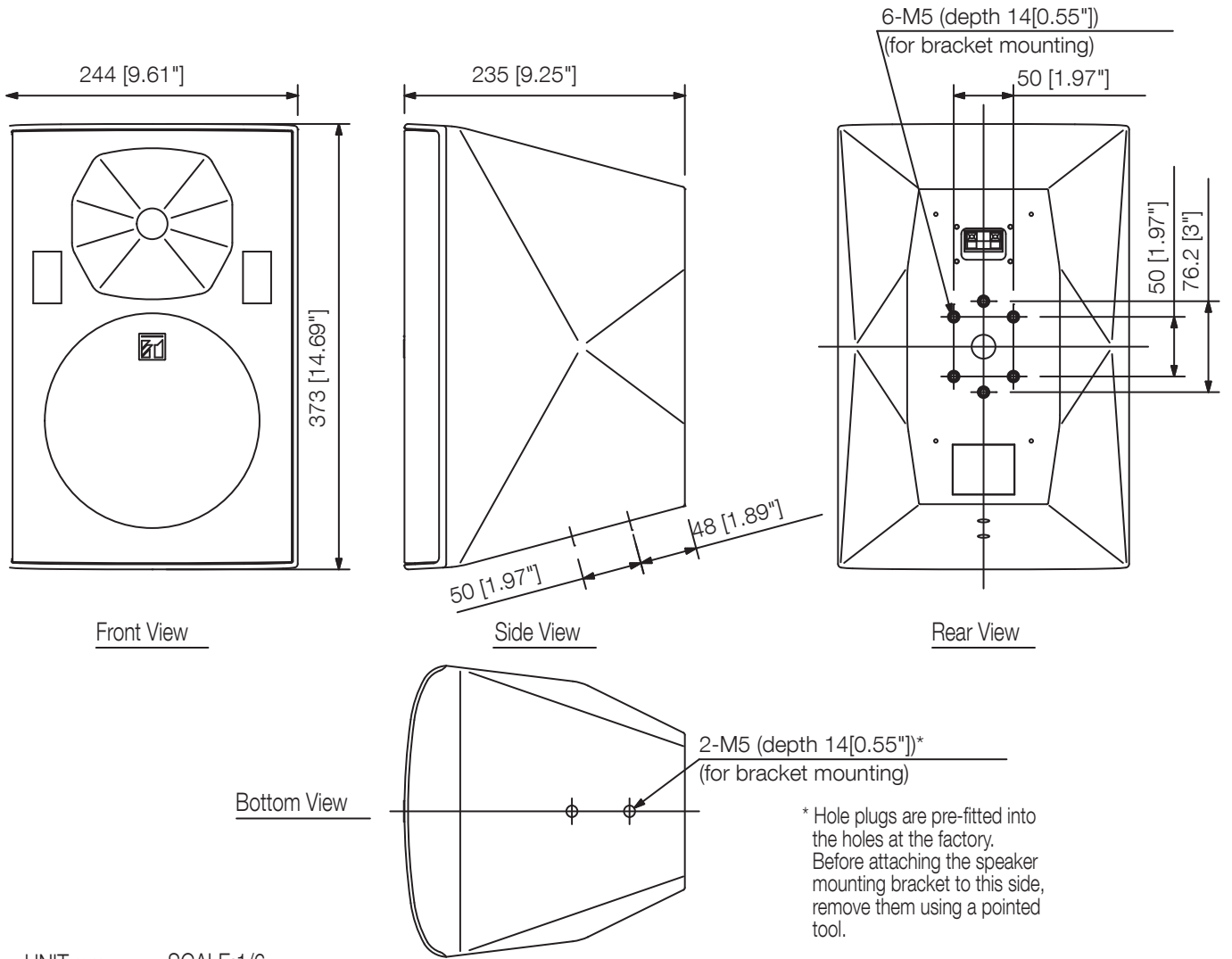

UNIT:mm

SCALE:1/6